

got sag & sway? then you need...

SuperSprings®



- Vehicle maintains a smooth ride whether loaded or unloaded
- Never needs adjusting like "air systems"
- Anti-sway feature increases handling and stability
- Increases the life of brakes, tires and existing suspension
- *Quick and easy to install!*



Before SuperSprings®



After SuperSprings®

SELF-ADJUSTING SUSPENSION STABILIZERS

Call us for applications not listed

MAKE	YEAR	PART #	MT. KIT REQ'D	RATING **	SPECIAL INSTRUCTIONS
GENERAL MOTORS					
C/K 1500 1/2 ton	73-87	SSA5 or 8	YES	2000, 3000	Use SSA8 for HD use
C/K 1500 1/2 ton (C/K changed to 2x4,4x4 in 1999)	88-98	SSA6 or 9	YES	2000, 3000	Use SSA9 for HD use
1500 1/2 ton 2x4,4x4	99-12	SSA5 or 8	YES	2000, 3000	Use SSA8 for HD use
1500 HD	01-10	SSA10	MXKT	3000	8 lug wheel
1500 HD	11-12	SSA16	MXKT	3000	8 lug wheel
K 2500 3/4 ton	73-87	SSA8 or 12	MXKT	3000, 4000	Order MXKT mounting kit
C/K 2500 3/4 ton (with factory top overloads)	88-00	SSA16 or 13	NO*	3000, 5000	*If no factory overload - MXKT required
C/K 2500 3/4 ton (without factory top overloads)	88-00	SSA16 or 13	MXKT	3000, 5000	Order MXKT mounting kit
2500 HD, 3500 HD 2x4,4x4 (no factory top overloads)	01-10	SSA10 or 15	MXKT	4000, 5000	Order MXKT mounting kit
2500 HD 2x4,4x4 (no factory top overloads)	11-12	SSA16 or 13	MXKT	4000, 5000	Order MXKT mounting kit
C/K 3500 1 ton HD,WT,UT, Cab Chassis (with factory top overloads)	91-02	SSA22	NO	5000+	
C3500 HD (no factory top overloads)	88-00	SSA16 or 13	MXKT	3000, 5000	Order MXKT mounting kit
C3500 HD/WT SRW/DRW (with factory top overloads)	02-10	SSA10 or 23	NO	4000, 5000	Use SSA23 for HD use
C3500 HD/WT SRW/DRW (with factory top overloads)	11-12	SSA16 or 13	NO	5000+	SSA13 for extra HD commercial appl.
C3500 HD Cab/Chassis	01-12	SSA23	NO	5000	Trim rear shackle legs for upper bolt use
C4500 / C5500	03-10	SSA22 or 17	NO	6000 +	C5500 use SSA17 only
TAHOE, YUKON 1/2 ton	92-99	SSA5 or 8	YES	2000, 3000	Use SSA8 for HD use
YUKON XL 3/4 ton	92-04	SSA8	YES	3000	
AVALANCHE 3/4 ton only	02-04	SSA8	YES	3000	
S-10 PICK-UP / SONOMA (use upper shackle roller position in front)	82-03	SSA2 or 7	NO	1800, 3000	SSA7 for HD use
COLORADO / CANYON	04-12	SSA3	NO	1800	
K5 BLAZER / JIMMY / BRAVADA	73-94	SSA5 or 8	YES	1800, 3000	Remove factory bumpstops
SUBURBAN 1500 (if rear a/c use SSA7*)	73-01	SSA8*	YES	2000, 3000	SSA8 for HD use. Always avoid A/C lines
SUBURBAN 2500	73-12	SSA8	YES	3000	MUST Avoid A/C lines
G-1500 SAVANA / EXPRESS VAN (& Conversion Van)	96-12	SSA14	YES	3000	Short shackle rear - AVOID a/c lines
G-2500 SAVANA/EXPRESS VAN	96-12	SSA8 or SSA12	YES	3000, 4000	SSA12 for HD use - AVOID a/c lines
G-3500 SAVANA/EXPRESS VAN	96-12	SSA12	YES	4000	Square shackle to rear
EXPRESS 139" 159" 177" WB CUTAWAY 3500	96-12	SSA16 or 13	NO	3000, 5000	SSA13 for HD. Check vertical clearance
EXPRESS 159" WB CUTAWAY 4500	96-12	SSA23 or 24	NO	4000, 5000	SSA24 for HD. Check vertical clearance
ASTRO / SAFARI VAN (steel multi-leaf) - special shackle reqd.	96-05	SSA2 or 7	YES	1800, 3000	Special order short shackles for rear
W-Series 3500/4500/5500 (for 08-11 models remove front spring-clip)	00-11	SSA22	NO	5000+	(08-11 Diesels require mod. to PSP1)
DODGE/STERLING/CHRYSLER					
RAM 1500 1/2 ton PICKUP	72-02	SSA5 or 8	YES	2000, 3000	Use SSA8 for HD use
RAM 1500, 1/2 ton PICKUP	03-08	SSA6 or 9	YES	2000, 3000	Use SSA9 for HD use
RAM 1500, 1/2 ton PICKUP (coils in the rear)	09-12	SSC50	N/A	2000	adds 30% capacity
RAM 2500, 3/4 ton PICKUP (with/without top overloads)	94-02	SSA22	NO	4000	
RAM 2500, 3/4 ton PICKUP (with factory overloads)	03-07	SSA23	NO	5000	
RAM 2500, 3/4 TON PICKUP (no factory overloads)	03-12	SSA10 or 15	YES	4000, 5000	Use SSA15 for HD use
RAM 3500, 1 ton PICKUP (with factory overloads)	94-02	SSA22	NO	4000	
RAM 3500, 1 ton PICKUP (no factory overloads)	94-02	SSA22 or 25	NO	4000, 5000	SSA25 for EXTRA HD use only
RAM 3500 / 3500HD SRW/DRW PICKUP (with/without factory overloads)	03-12	SSA23	NO	5000	
RAM 3500 SRW 1 ton PICKUP (no factory overloads)	03-07	SSA10 or 15	YES	4000, 5000	Use SSA15 for HD use
RAM 4500 / 5500 HD (Use SSA33 for 5500HD extra heavy duty use only)	07-12	SSA23/32/24/33	NO	5000 +	Use SSA24/33 for EXTRA HD use only
STERLING 360 LCF	08-09	SSA22	NO	5000+	
DAKOTA PICKUP 2 WD	87-04	SSA2	NO	1800	
DAKOTA PICKUP 4 WD	87-04	SSA2	YES	1800, 2000+	
DAKOTA 2x4,4x4	05-11	SSA2 or 7	YES	1800, 2000+	Use SSA7 for HD use
DURANGO	98-03	SSA3	NO	2000	Use upper shackle bolt hole in front
DODGE VAN B100 / B150	70-02	SSA7	YES	1800, 3000	
DODGE VAN B200 / B250	70-02	SSA7 or 11	YES	2000, 3000	Use SSA11 for HD use
DODGE VAN B300 / B350 / 15 SEATER VAN	70-02	SSA8 or 12	YES	3000, 4000	Use SSA12 for HD use
DODGE SPRINTER 2500 (factory steel leaf models)	03-09	SSA11	YES	3000	08-09 call factory for mt.kt. Risers
DODGE SPRINTER 3500 (factory 3 leaf non-parabolic leaf springs)	03-09	SSA12	YES	4000	Square shackle to front
DODGE SPRINTER 3500 SDD (2 blade parabolics)	08-09	(no application)			

FORD

F150 (dual gas tank models only)	86-99	SSA7	YES	3000	
F250, F350 (dual gas tank models only)	86-99	SSA7 or 12	NO	3000, 4000	Use SSA12 for HD use
F-150 1/2 ton Pick-up	73-08	SSA5 or 8	YES	2000, 3000	Use SSA8 for HD use
F-150 1/2 ton Pick-up	09-12	SSA5	YES	2000	Use upper roller position in front
F-150 1/2 ton Pick-up	09-12	SSA28	NO	3000	Use short square shackle to the front
F-150 1/2 ton Heavy Duty Payload Package Pick-up (8200 GVWR)	04-12	SSA9	YES	4500	
F-250 3/4 ton PICKUP (Light Duty under 7500 GVWR)	73-99	SSA8 or 12	YES	3000,4000	MTKT tight fit around factory bracket
F-250, F-350 (Super Duty over 7500 GVWR - no factory overload above)	80-07	SSA16 or 13	NO	3000, 5000	Use SSA13 for HD use
F-250, F350(Super Duty over 7500 GVWR - with factory overload above)	80-07	SSA16 or 22	NO	4000 +	Use SSA22 for extra HD use only
F-250, F350 Pick-up(with/without top overloads)	08-10	SSA10 or 15	NO	4000 +	Use SSA15 for extra HD use only
F-250, F350 Pick-up(without top overloads)	11-12	SSA16 or 13	YES	4000 +	Use SSA13 for HD use
F-250, F350 Pick-up(with top overloads)	11-12	SSA16	NO	4000 +	
F-450 Pick-up (with factory overload above)	08-12	SSA22	NO	4000 +	
F-250 Chassis Cab (with factory top overload)	88-06	SSA22	NO	4000 +	
F-350 Cab/Chassis (S/D over 7500 GVWR - with factory overload)	99-12	SSA22	NO	4000+	
F-450, F550 Cab/Chassis (S/D over 7500 GVWR - with factory overload)	99-12	SSA22 or 17	NO	4000 +	Use SSA17 for F550 use
RANGER	83-09	SSA5 or 8	YES	2000, 3000	Use SSA8 for EXTRA HD use
RANGER (Avoid sensor when installing mounting kit)	10 -12	SSA30 or 31	NO	2000, 3000	Use SSA31 for EXTRA HD use
BRONCO	78-96	SSA5 or 8	YES	2000,3000	Use SSA8 for EXTRA HD use
BRONCO II	84-90	SSA5	YES	2000	
EXPLORER / MOUNTAINEER	98-01	SSA3	NO	2000	Use upper shackle bolt hole in front
SPORT TRAC 2x4/4x4	98-06	SSA3	NO	2000	Use upper shackle bolt hole in front
E-150, E-250 1/2, 3/4 TON VAN	75-07	SSA8 or 12	YES	3000+	Use SSA8 for E150 use
E-150 1/2 TON VAN	08-12	SSA8	NO	3000	
E-350 1 ton VAN	75-07	SSA8 or 12	NO	3000, 4000	Use SSA12 for HD use
E-250 / E-350 VAN	08-12	SSA8 or 12	NO	3000, 4000	Use SSA12 for E350 use
E-350 CUTAWAY BOX	92-12	SSA12 OR 22	NO	4000, 5000	Use SSA22 for EXTRA HD use only
E-450 CUTAWAY BOX	01-12	SSA22	NO	5000+	
E-350 Class C RV	01-12	SSA22 or 25	NO	5000+	Use SSA25 for HD use
E-450 Class C RV - (Motorhome models differ ensure clearances)	01-12	SSA22 or 25	NO	5000+	Use SSA25 for HD use
FORD TRANSIT CONNECT	10 -12	SSA29	NO	3000	

Call us for applications not listed

ISUZU, MAZDA, NISSAN, TOYOTA

ISUZU NPR / NPR-HD (for 08-11 models remove front spring-clip)	00-12	SSA22	NO	5000 +	08-11 Diesel requires mod. to PSP1
MAZDA PICKUP - B Series	94-08	SSA5 or 8	YES	2000, 3000	Use SSA8 for HD use
NISSAN PICKUP	86-97	SSA2	NO	1800	
NISSAN FRONTIER PICKUP 2x4 CREWCAB	98-04	SSA2 or 7	NO	1800, 3000	SSA7 for HD.
NISSAN FRONTIER PICKUP 4x4 CREWCAB	98-04	SSA2 or 7	YES	1800, 3000	SSA7 for HD.
NISSAN FRONTIER PICKUP 2x4,4x4, CREWCAB (trim bumpstop)	05-12	SSA1	YES	2000	Square shackle to rear-use upper hole
NISSAN XTERRA	00-07	SSA1	NO	2000	
NISSAN TITAN	04-12	SSA20	NO	3000	Includes special mounting kit
NISSAN UD LCF 1200,1300,1400,1800	00-12	SSA22	NO	5000 +	
NISSAN NV 1500	11-12	SSA28	NO	4,000	
NISSAN NV 2500, 3500	11-12	SSA28 or SSA12	YES	4200, 5000	
TOYOTA PICK-UP 2x4	80-94	SSA1	NO	1800	
TOYOTA PICK-UP 4x4	80-94	SSA1	YES	1800	
TOYOTA TACOMA 2x4	95-00	SSA2 or 7	NO	1800, 3000	Front shackle use upper bolt-hole
TOYOTA TACOMA 2x4 (square shackle to rear, use upper bolt hole)	01-12	SSA1 or 7	NO	1800, 3000	SSA7 for HD use
TOYOTA TACOMA 4x4/2x4 Prerunner (short shackle in rear)	95-04	SSA18	NO	2000	MTKT incl - Remove bumpstop
TOYOTA TACOMA 4x4/2x4 Prerunner (square shackle-rear-upper hole)	05-12	SSA19	NO	2000	MTKT incl - Remove bumpstop
TOYOTA TUNDRA	98-06	SSA8	YES	3000	Trim bumpstop 1"
TOYOTA TUNDRA (All new body style)	07-12	SSA4	NO	3000	MTKT incl - Remove bumpstop
TOYOTA T100	93-98	SSA2 or 7	NO/YES*	1800, 3000	SSA7 for HD use *4x4 needs MTKT
TOYOTA TUNDRA (All new body style)	07-12	SSA4	NO	3000	MTKT incl - Remove bumpstop
TOYOTA T100	93-98	SSA2 or 7	NO/YES*	1800, 3000	SSA7 for HD use *4x4 needs MTKT

** RATING IS TOTAL OF VEHICLE PAYLOAD PLUS SUPERSPRING CAPACITY - NEVER EXCEED VEHICLE GVWR

NOTE: Where Mounting Kit is required, order part number MT-KT separately

SuperSway-Stops

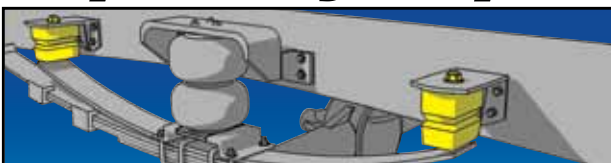

Designed to deliver Enhanced Stability for your FORD SUPER DUTY 3/4 OR 1 TON PICKUP with factory contact type auxiliary springs and fitted with air springs.

CUTTING EDGE ANTI-SWAY SUSPENSION SOLUTION

incorporating micro cellular polyurethane foam

2012 APPLICATION SHEET

Make	Year	Part #
FORD		
Ford F-250 Super Duty ~ with factory overload spring above spring pack	00-12	SSS-1
Ford F-350 Super Duty ~ with factory overload spring above spring pack	00-12	SSS-1

got front end sag? get...

got rear end sag & sway? get...

SumoSprings

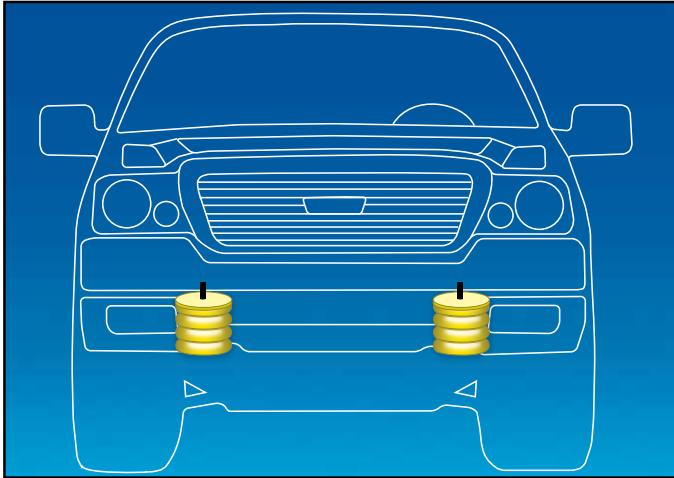

For trucks with snow plows, winches and other front-mounted accessories.

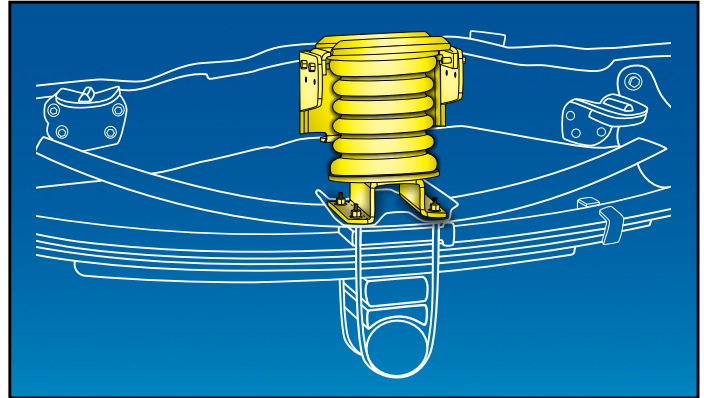

For trucks with campers, trailers, commercial bodies and all other loads.

2012 APPLICATION SHEET (FRONT)

Make	Year	Part # 2x4	Part # 4x4
FORD			
F150	2004-2012	SSF-105	SSF-105
F250 / F350 Super Duty/Chassis Cab	1999-2004	SSF-101	SSF-103
F250 / F350 Super Duty/Chassis Cab	2005-2012	SSF-101	SSF-102
F450 / F550 SUPER DUTY	2005-2012	SSF-104	SSF-104
F 53 Class A Motor Home (16K-22K GVWR)	1990-2003	SSF-181	
F 53 Class A Motor Home (16K-22K GVWR)	2004-2010	SSF-180	
F 53 Class A Motorhome (16K-22K GVWR)	2004-2010	SSF-180	SSF-180
GENERAL MOTORS			
1500 SIERRA, SILVERADO	1999-2006		SSF-203
1500 SIERRA, SILVERADO	2007-2012	SSF-205	SSF-205
SUBURBAN, YUKON XL 2500	2000-2010	SSF-201	SSF-201
1500 HD, 2500/3500 SIERRA, SILVERADO, 2500/3500HD	2001-2010	SSF-201	SSF-201
2500/3500 HD SIERRA, SILVERADO	2011-2012	SSF-202	SSF-202
3500 SIERRA, SILVERADO Chassis Cab	2001-2010	SSF-201	SSF-201
Workhorse W20, W22, W24 Class A Motor Home	2001-2010	SSF-280	
DODGE			
RAM 1500 (4x4) Only	2006-2012		SSF-305
RAM 2500 HD	1994-2012		SSF-302
RAM 3500 Pick-up/Chassis Cab	1994-2012		SSF-302
RAM 3500 Pick-up/Chassis Cab	2007-2012	SSF-302	
RAM 4500/5500	2007-2012	SSF-303	SSF-303
JEEP			
JK Wrangler	2007-2012		SSF-401

2012 APPLICATION SHEET (REAR)

Make	Year	Part #
FORD		
F250 / F350 SUPER DUTY (2x4 & 4x4) - No 5th wheel	1999-2010	SSR-101
F250 / F350 SUPER DUTY (2x4 & 4x4) - No 5th wheel	2011-2012	SSR-103
F250 / F350 SUPER DUTY (2x4 & 4x4) - with 5th wheel	1999-2012	SSR-102
F450 / F550 SUPER DUTY (Cab & Chassis)	2005-2012	SSR-104
Ford F-53 Class A Motor Home (16K-22K GVWR)	1990-2004	SSR-181
Ford F-53 Class A Motor Home (16K-22K GVWR)	2005-2009	SSR-180
<i>(May exclude some Thor models due to LP gas line)</i>		
GENERAL MOTORS		
Pick Up Truck / Cab & Chassis		
Tahoe, 1500 Yukon (2x4 only)	2000-2006	SSR-204
1500 Suburban, 1500 Yukon XL (2x4 & 4x4)	2000-2012	SSR-204
Denali, Escalade, Coil rear (2x4 only)	2002-2006	SSR-204
Denali, Escalade, 1500 Yukon, Tahoe excluding XFE series (2x4 & 4x4)	2000-2012	SSR-204
2500 Suburban, 2500 Yukon	2000-2010	SSR-202
2500/3500 SIERRA, SILVERADO, 2500/3500HD (2x4 & 4x4)	2001-2010	SSR-201
2500/3500 SIERRA, SILVERADO, 2500/3500HD (2x4 & 4x4)	2011-2012	SSR-203
Motorhome		
P32, P37 (OEM rear bumpstop installed over spring pack)	1993-2004	SSR-290
Workhorse W20, W22, W24	2001-2010	SSR-280
DODGE		
RAM3500 (2x4 & 4x4)	2002-2012	SSR-301
JEEP		
JK Wrangler	2007-2012	SSR-401

Suspension Upgrades

Full Size Pickups / Work Trucks / Snow Plows Armored Cars / RVs